

# CONCRETE COLLAR APPLICATIONS

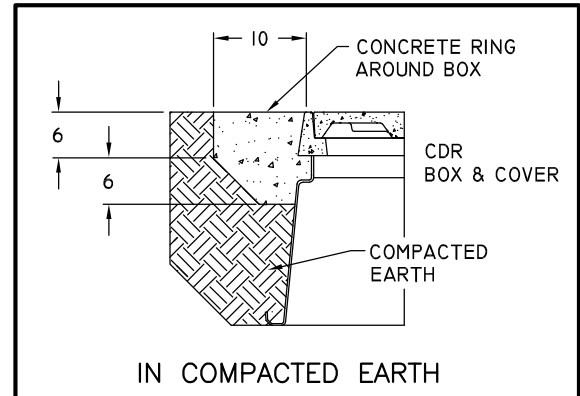
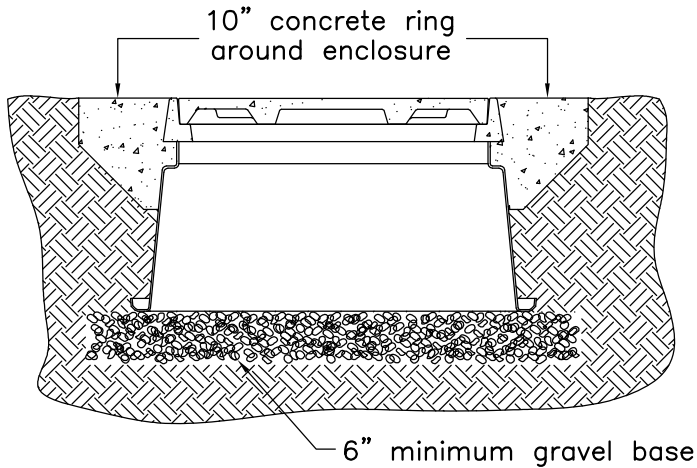

Concrete collars may be desired for installations in driveways, parking lots and off-roadway applications where subject to occasional non-deliberate traffic. This applies to boxes made from any material to provide added protection for the top lip. This is not necessary in grassy areas or areas subject to pedestrian traffic. However, it is recommended and is referred to as a "housekeeping apron". It prevents mower blades from contacting the edges of the box.

### Notes:

1. Concrete encasement to be 3,000 psi minimum.
2. Concrete encasement collar dimension, D, to be equal to design pavement depth.
3. Pavement and subgrade to be as shown on the engineering plans.

