

Integral Bracing Installation

Installation Guidelines for Internal Bracing:

Internal bracing may be warranted for any manufacturer's underground enclosure. If 95% compaction is required or if heavy vehicles are going to be present during construction and/or throughout the life of the enclosure, internal bracing during back-filling operations will ensure minimal box sidewall deflections. This installation practice applies to enclosures made from any material to maintain the original sidewall geometry.

Supports should be 2 x 4 or similar material sized to hold at mid-depth.

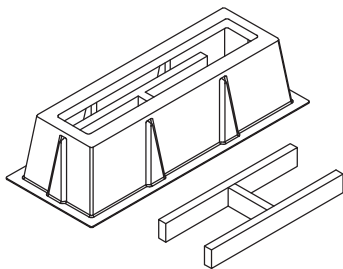

UP TO 2461

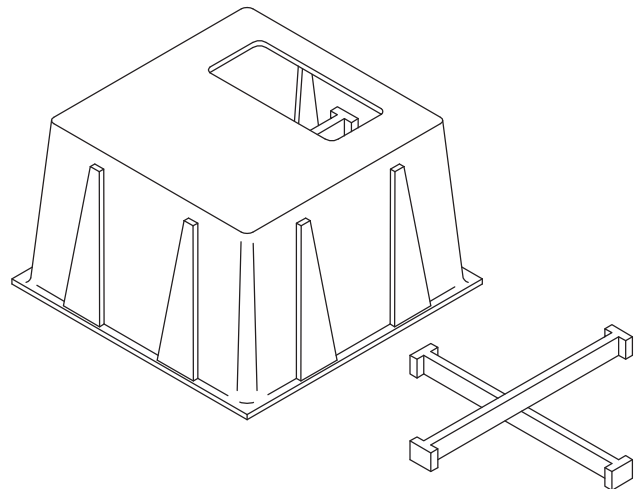

4444 AND SMALLER

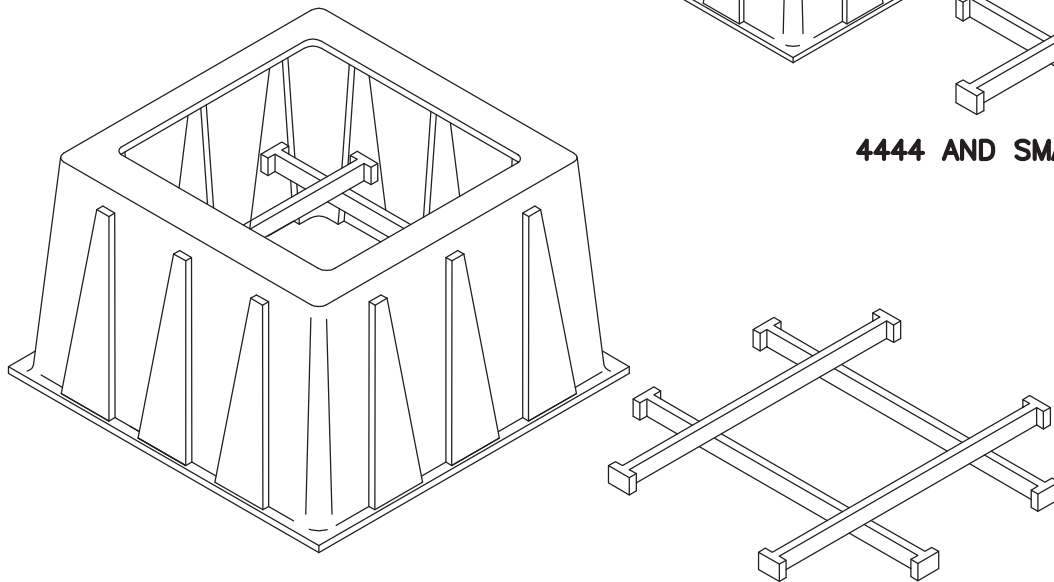

LARGER THAN 4444

Note: Regardless of the design and materials used in the construction of the product, the bracing required is the same.

